

REV.	DESCRIPTION	DATE	MODIFIÉ PAR:	VERIFIÉ PAR:
B	Revision GED	05/01/2021	D.TAULIAUT	
A	Création du plan suivant pieces fabriquees	07/10/2014	OPP	

REVISIONS

Matériaux:	
Epaisseur:	
Traitement:	
Finition:	
Masse (Kg):	116380.49

		Code article: <b>CAOEQUER</b>		Révision: <b>B</b>
		Nom: OPP - ACOM	Contrôlé	Validé
		Date: 03/10/2014		
		Signature:		
Appareil: <b>Cuiseur a pates</b>				
Pièce - article: <b>ENS cuiseur a pates</b>				
Configuration: <b>21212</b>				
Plan N°: 21202-21212			SCALE:1:8	SHEET 1 OF 3



unité: mm [inch]

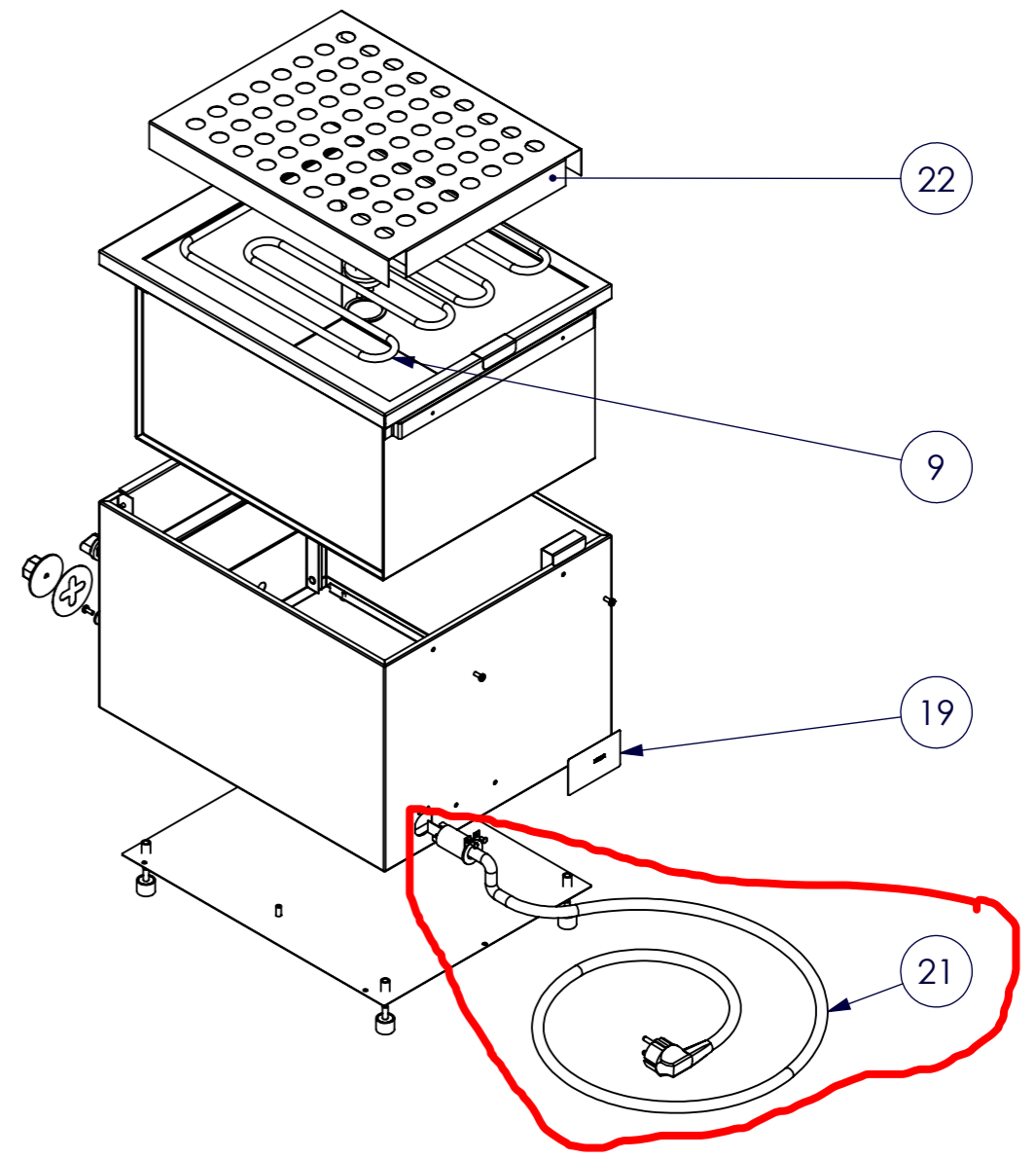
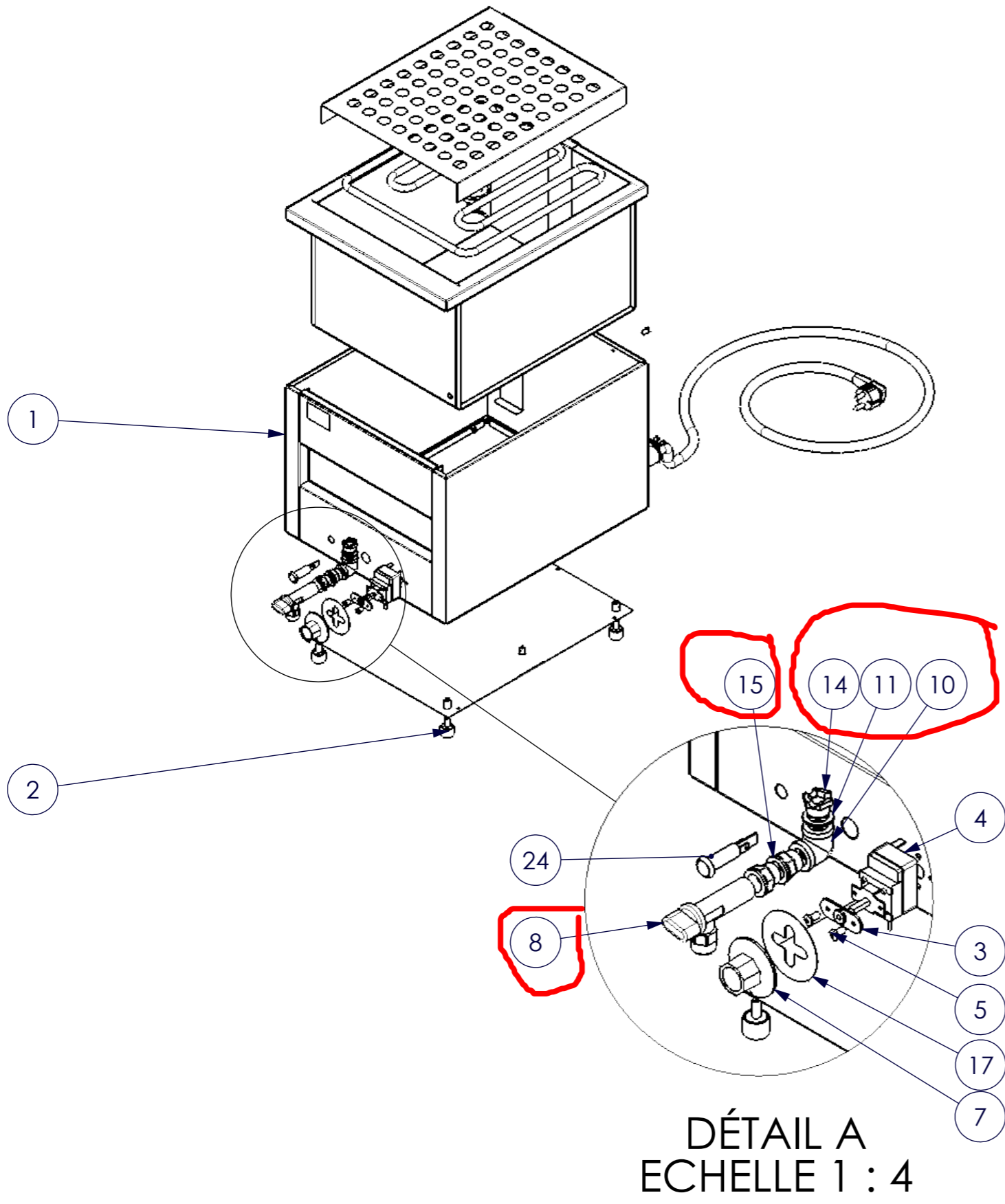

Matériaux:
Epaisseur:
Traitement:
Finition:
Masse (Kg): 116380.49
unité: mm [inch]

	Code article: <b>CAOEQUER</b>		Révision: B
	Nom: OPP - ACOM	Contrôlé	Validé
	Date: 03/10/2014		
	Signature:		
Appareil: Cuiseur a pates			
Pièce - article: ENS cuiseur a pates			
Configuration: 21212			
Plan N°:		SCALE:1:8	SHEET 2 OF 3 A3

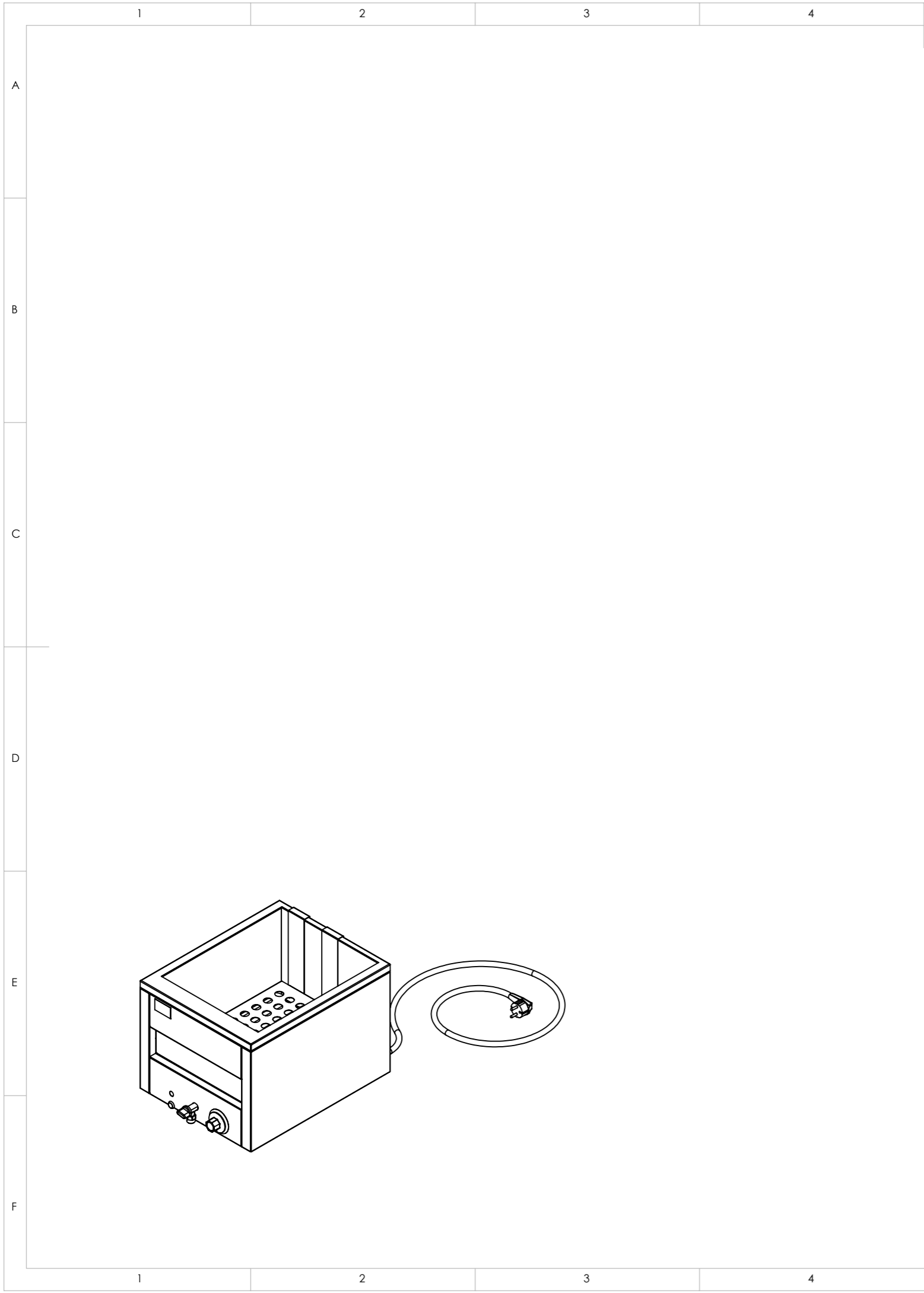

No. ARTICLE	Pièce - article (désignation):	21212/Quantité	Code article:
1	ENS Tolerie Cuiseur a pates	1	BMTOL05
2	ELASTOP PLOTS 20x15 EPDM	4	XPEMB01
3	Joint isolant universel	1	XJOI01
4	Thermostat de régulation	1	XETHE101
5	vis BZ, M4 - 10 , ISO 7045	4	N/A
6	Tapping screw DIN 7049-ST3.5x9.5-C-H	5	
7	bouton temperature	1	IGBOU04
8	Robinet 1/4 de tour	1	BMROB01
9	Résistance blindée	1	BMR05362
10	Coude femelle - femelle 90°	1	BMCOUD01
11	joint fibre 16x24x2	2	BMJOI3/4
12	joint rouge 15x10x2	1	BMJOI3/8
13	joint fibre 37,3x45x2	1	BMJOI02
14	Mamelon spécifique 3/8 de vidange	1	BMMEHD10
15	Mamelon M/F égal	2	BMRACMF38
16	Embal. Complet PGM	1	XCARPGM
17	Cadran gradué universel	1	XEMIN10
18	Etiquette "IMPORTANT"	1	BMSIG1
19	Plaque de firme	1	XSFIR01
20	Façade 288x77 Compact line	1	CLBAN02
21	Cordon secteur complet	1	XECOROEC
22	Grille de protection resistance	1	BMGRI04 - >BMGRI07
23	rivet standard _ DIN7337 - 3,2 x 6	2	N/A
24	Voyant ambre LED 230V D10	1	XEVOY11

Matériaux:		Code article: <b>CAOEQUER</b>		Révision: B
Epaisseur:		Nom: OPP - ACOM	Contrôlé	Validé
Traitement:		Date: 03/10/2014		
Finition:		Signature:		
Masse (Kg): 116380.49	Appareil: Cuiseur a pates			
 unité: mm [inch]	Pièce - article: <b>ENS cuiseur a pates</b> Configuration: 21212			
	Plan N°:	SCALE:1:10	SHEET 3 OF 3	A3